

# SERVICE, DISASSEMBLY AND RE-ASSEMBLY **PulseGuard®**

## PipeHugger

**Damper Type** / **Volume** / **Design Pressure** / **Membrane Type, Diameter & Length - Material** / **Piping Base** or **Direct Connect** / **Wetted Metal**  
 PHr - HP / ... i = in3 / ... p = psi / D=Liquid Bladder mm Ø Roll mm N, E, H, V, /+ PB A" B" etc. --"# or --" npt / 316ss, A20, HC276, etc  
 Under Licence From Martin Packer since 1963  
 Pt. Nbr. - Identification : PHr - LP / --Lt = Liters / ... Br = Bar / Ex EG: D 450 y 120 · E /+ PB 6"x6" or 10" 600# or 8" BW | HC276, etc  
 D=Liquid Bladder

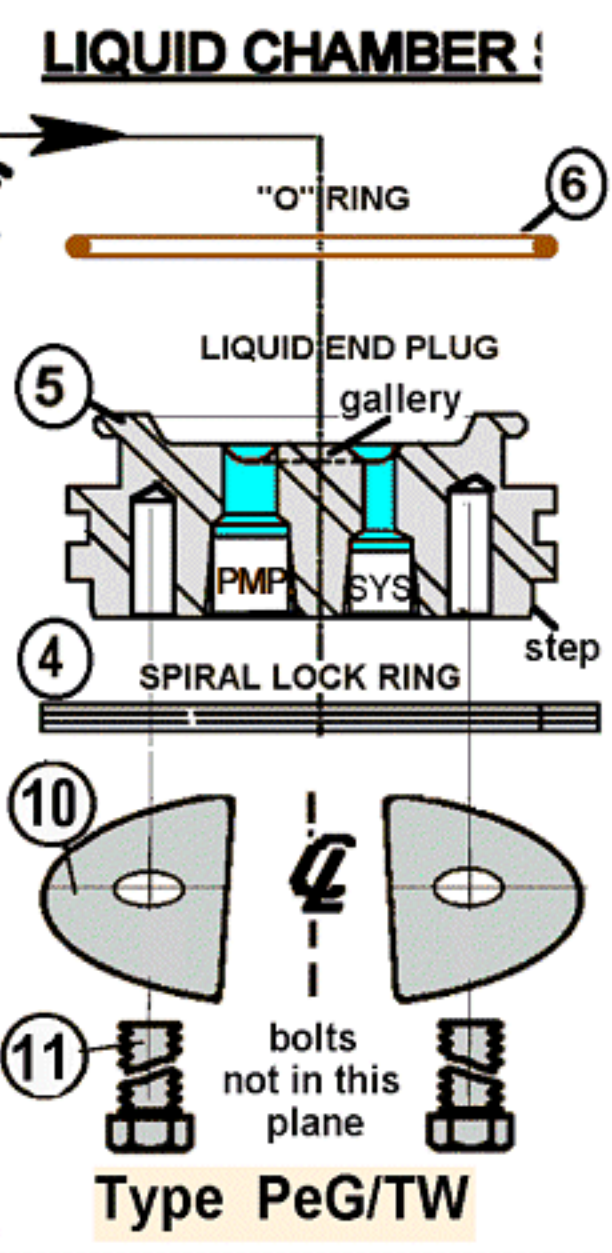
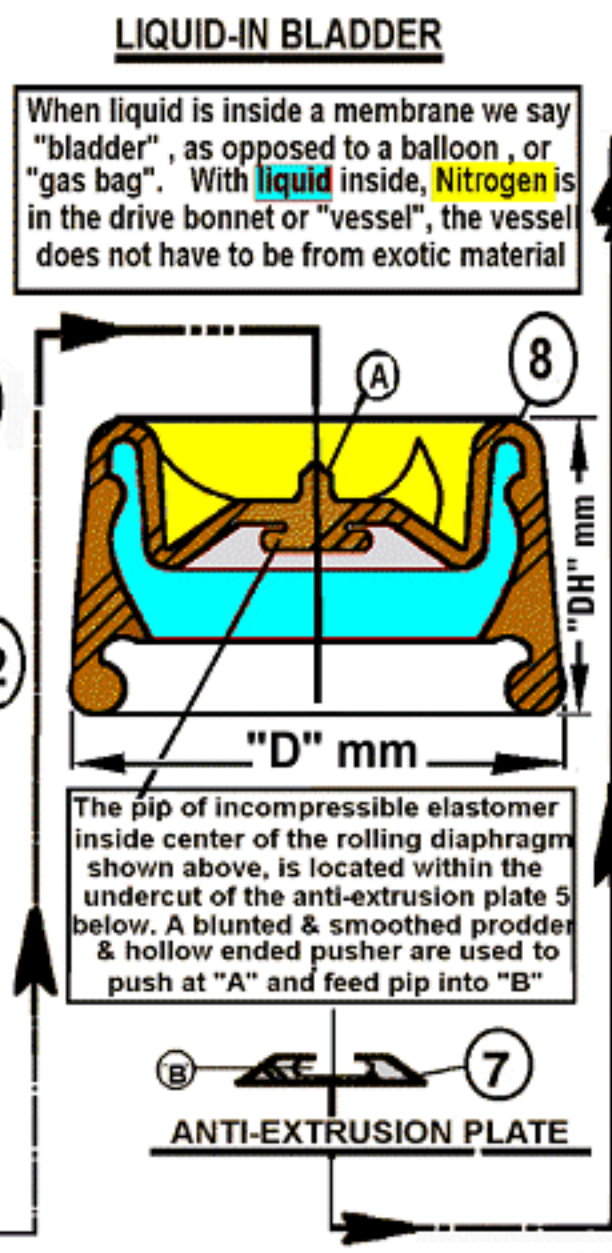
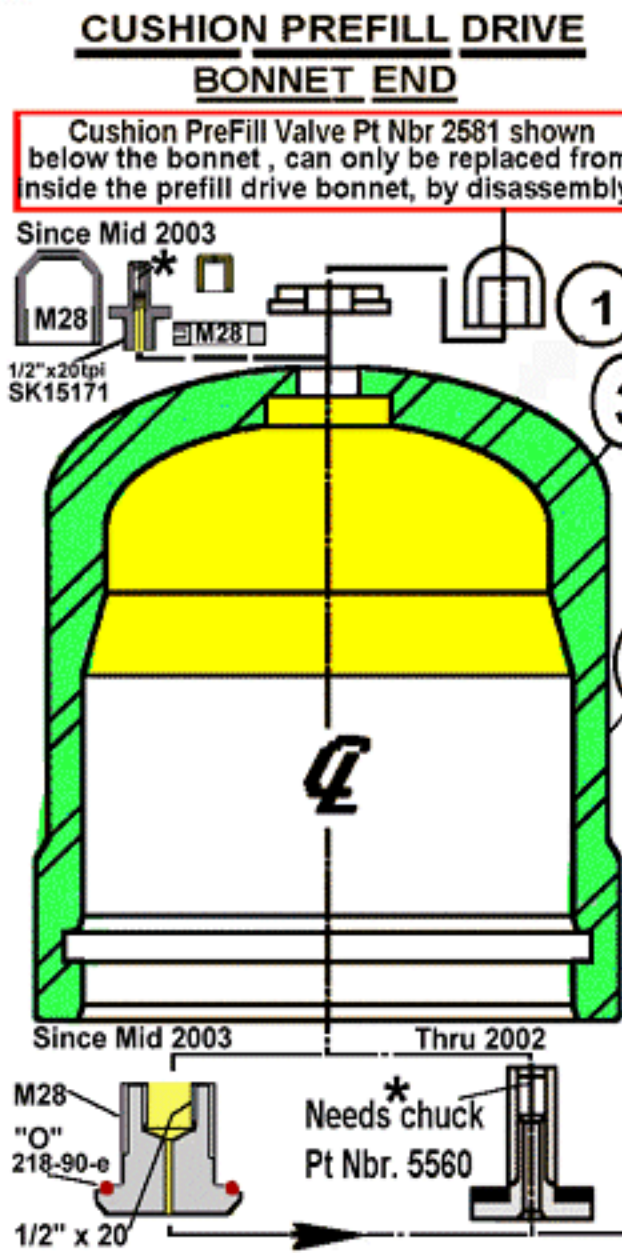

- ANSI A53 Non SA Mt.
  - SA 106 Gr. B
  - SA 516 Gr 60 WPA
  - Wrought Metal
  - Separator Membrane
  - Elastomer Liner Same Material as Bladder but harder
  - Process Liquid
  - Oxygen Free Dry Nitrogen "O.F.N."
  - High cost material
- 1, Nitrogen Pre-Filling Valve
  - 2, Nitrogen Bonnet
  - 3, Bonnet Head
  - 4, Segmental or Spiral Lock Ring
  - 5, Liquid End Plug
  - 6, Diametral "O" Seal
  - 7, Anti Extrusion Plate
  - 8, Bladder (Liquid Inside)
- The following materials are normal inventory, or short lead time.  
 N=Butadiene Acrylo Nitrile  
 E=Ethylene Propylene Ter-Polymer  
 V=Fluora Carbon Elastomer.
- Low & High temperature, +Food/Drug vers. available.
- 9, Corner Filling Ring (If Reqd.)
- TO ORDER SPARES  
 SK=Spares Kit Including Seals and Pre-Fill valve  
 Example :- SK-B24x80-E

**PulseGuard®** wishes to review its products; we will install a spares kit, test, & recertify your damper, for the same cost as a spares kit. If \$40.00 has been saved on the original purchase price, by using a "pin core valve," you may wish to have the factory convert your damper to the "Strut Valve" at the bottom of this page. Please Call for a Return Materials Authorization Number, - An "RMA", aka "RGA".

**PIN CORES** ARE JUST CHECK VALVES & PROVIDE NO CONTROL **REQUIRE \$750**

**"PRE-FILLING" ASSEMBLY** **\$250** AND **YOU CAN NOT STOP WHAT'S IN THE HOSE GOING INTO THE DAMPER.**

**CYLINDER REGULATOR** **\$500**

HELP LINES  
**PulseGuard®**  
 US Toll Free 1-888-Dampers 326-7377  
 Fax Free 1-888-825-5357  
 International -01-910-270-2737  
**Guard** against **Pulsation**

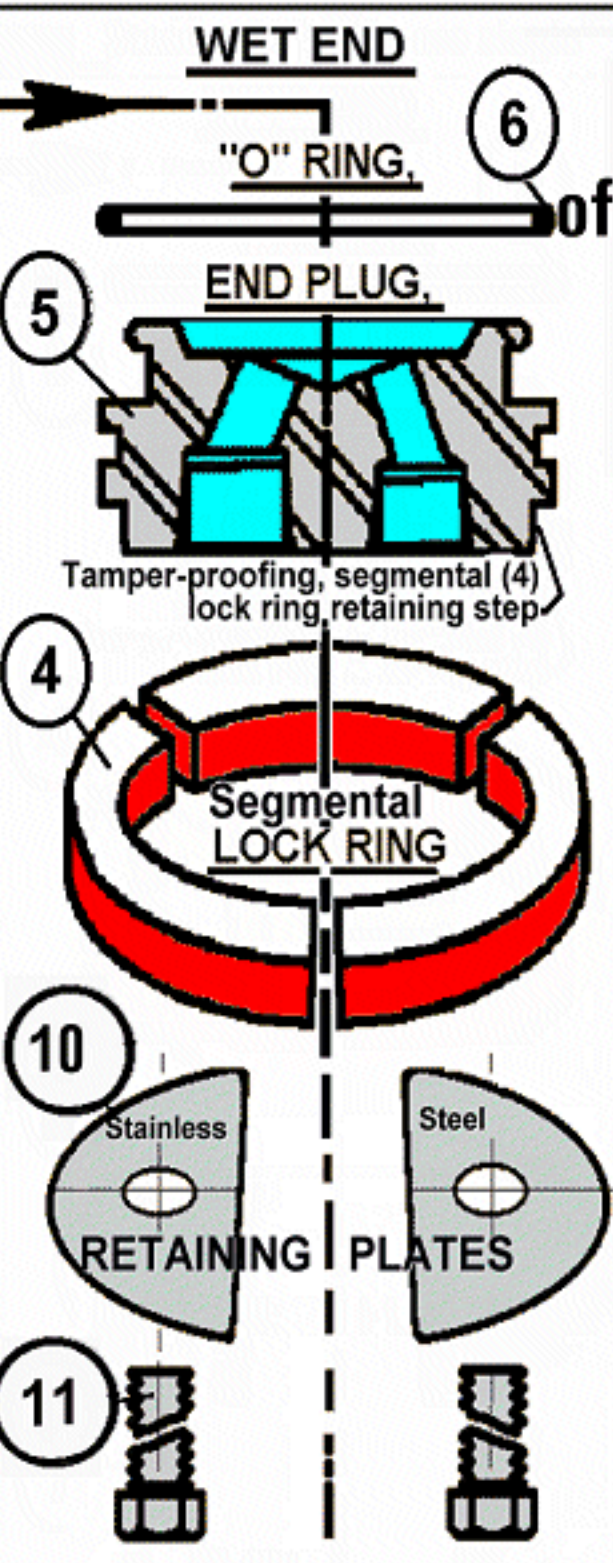
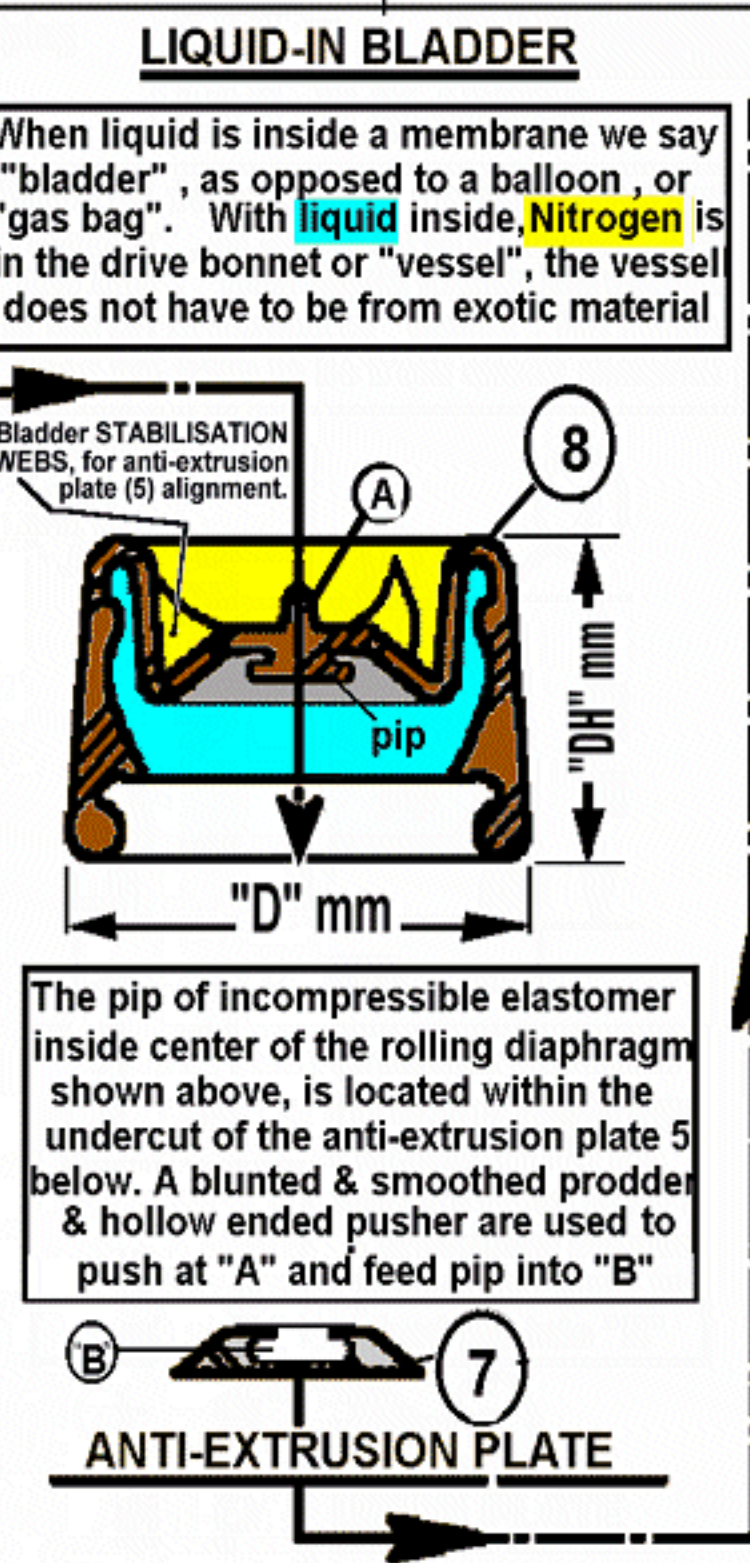
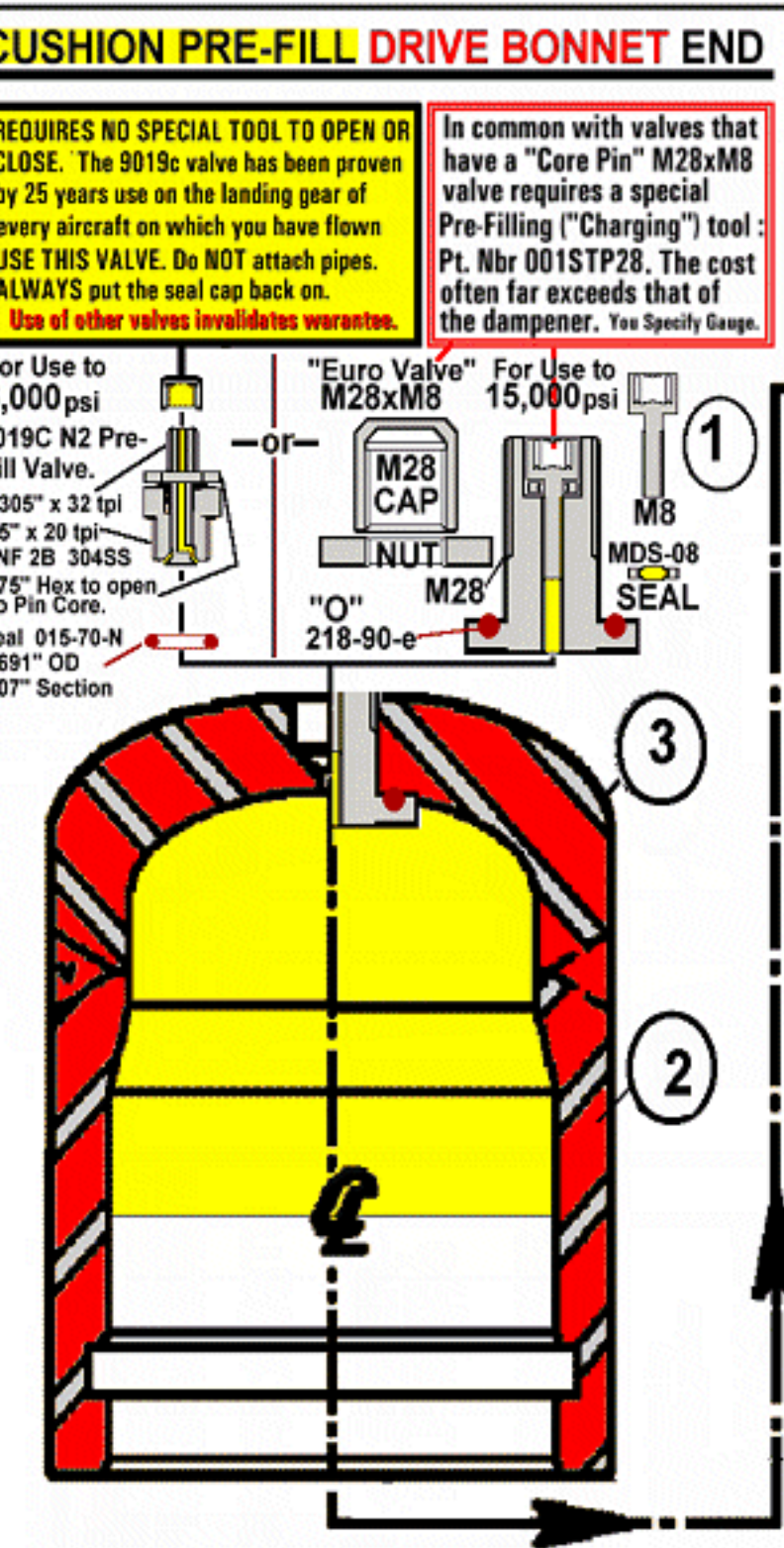

## Slashing the cost of exotic specifications

### PHr-Lnd./-/-

Elastomer Liner Same Material as Bladder but harder

Steel

END PLUG

SPIRAL LOCK RING

High Cost Materials Tantalum etc.

But the standard PulseGuard strut valve way, saves a bundle, and is safer.

Strut valve, closed & opened with a wrench, you have.

40 YEARS AIRCRAFT PROVEN. **REQUIRES**

Save 600 **\$150**

N2 Cylinder "Bull nose" nipple, LH 7/8" BSP // connector  
 1/4" npt  
 1/4" Gauge npt  
 1/4, 1/4, 1/4" T"  
 Pre-Fill Tool 001-9-0-009  
 3/4" A/F