

# "PUG/XL-RF" PumpGuard "Clear-Flo" Extra Charge Special version for in place flush.

Pulse Damper for viscous liquids & slurries in suction and LP discharge lines

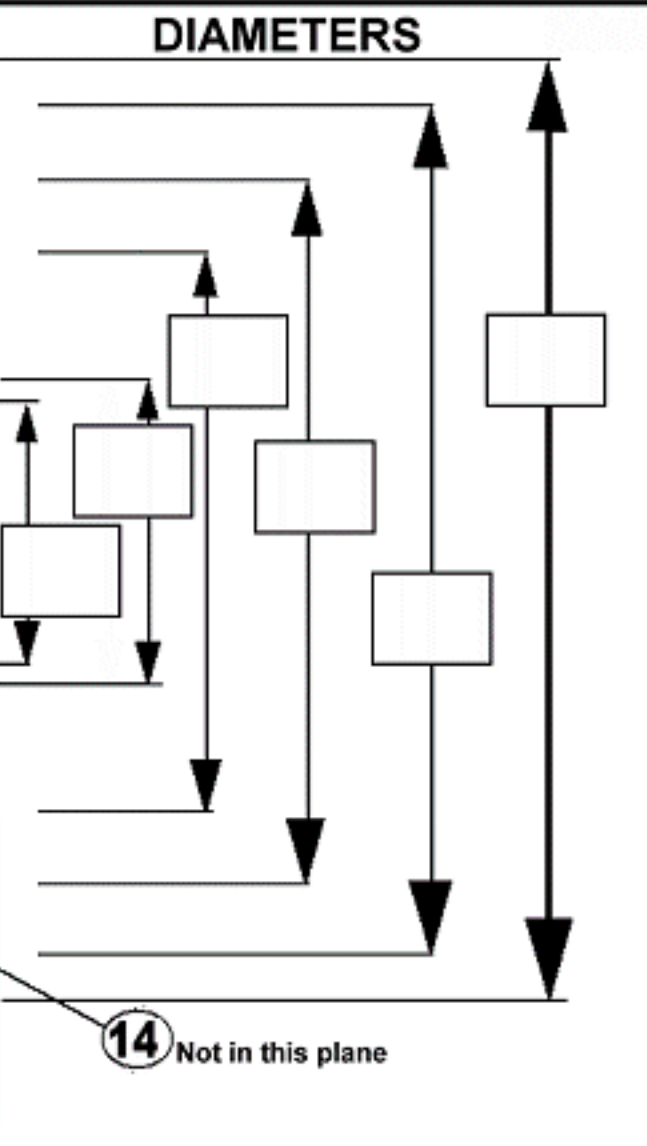

for use where pcd of stud bolts causes circle round OD of tapped stud holes to fall outside step diameter of end plug

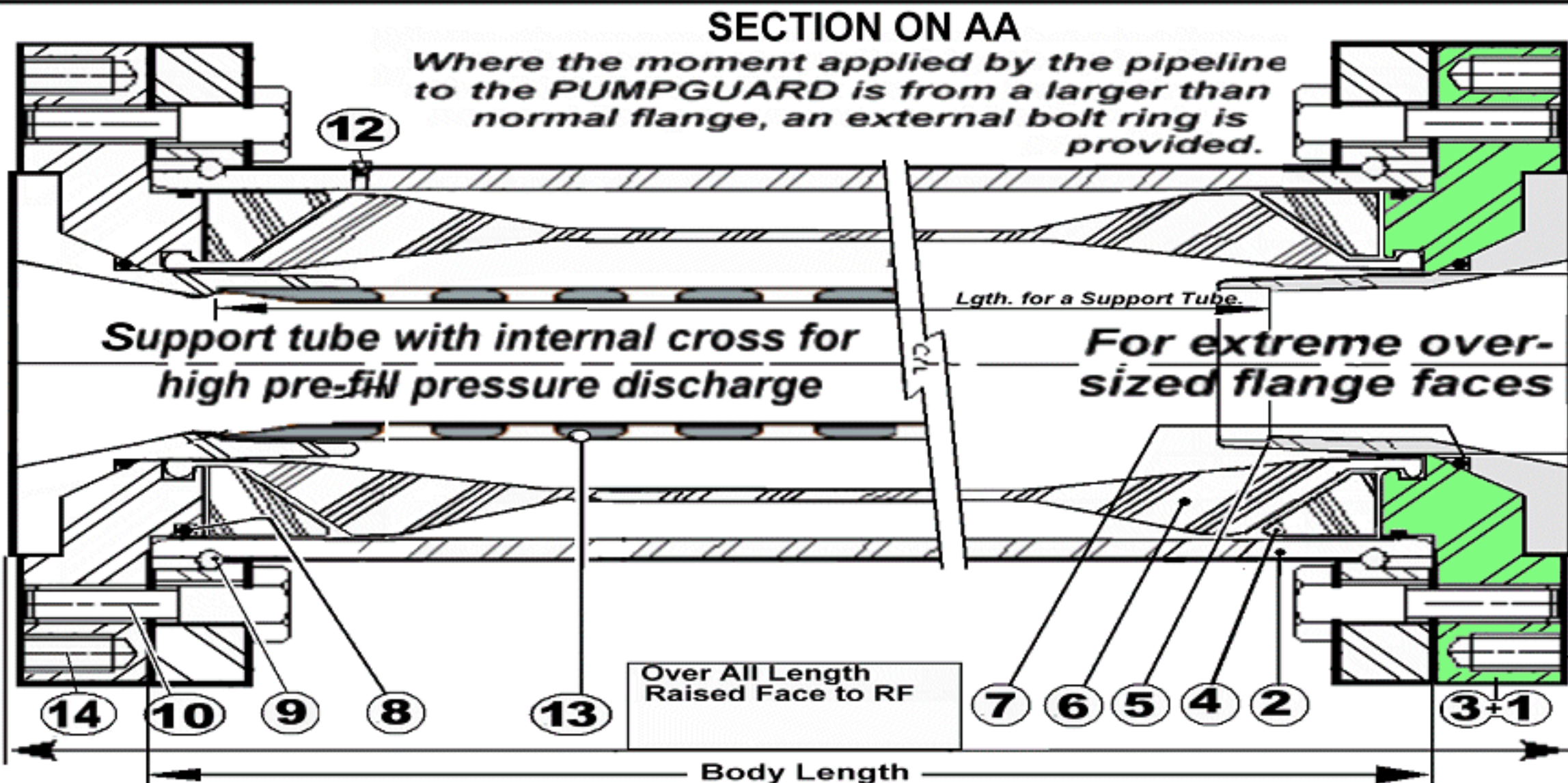
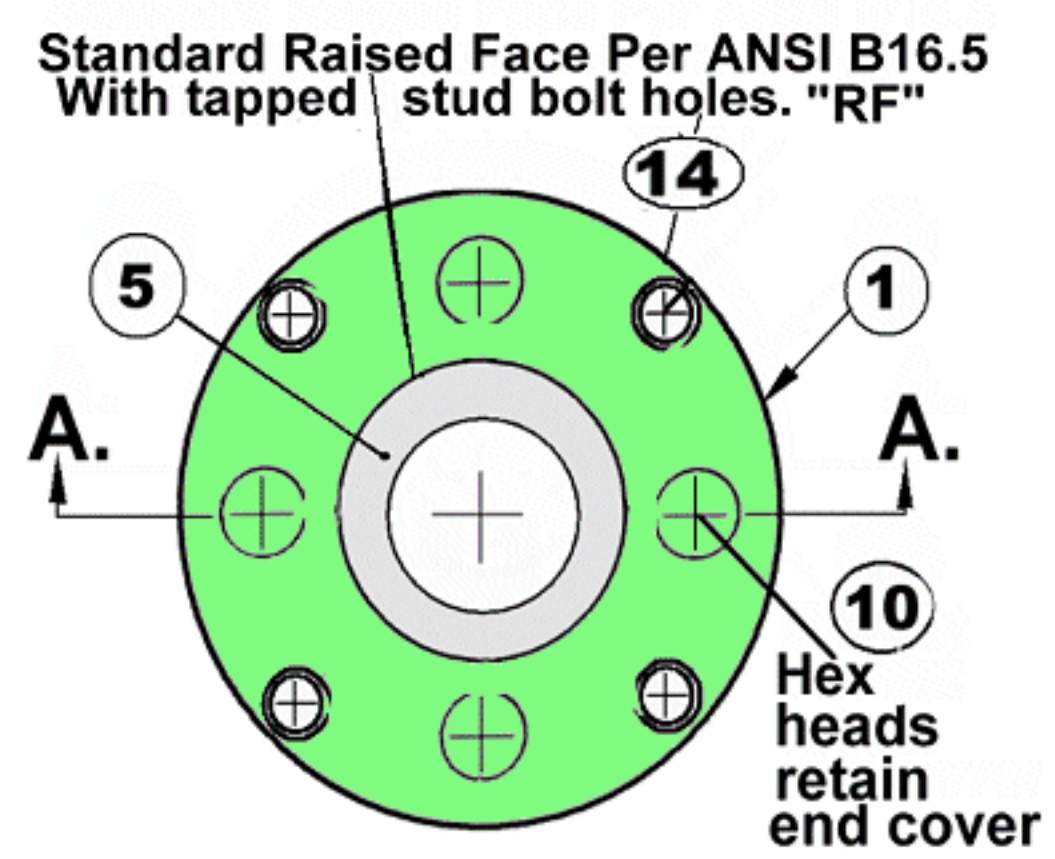
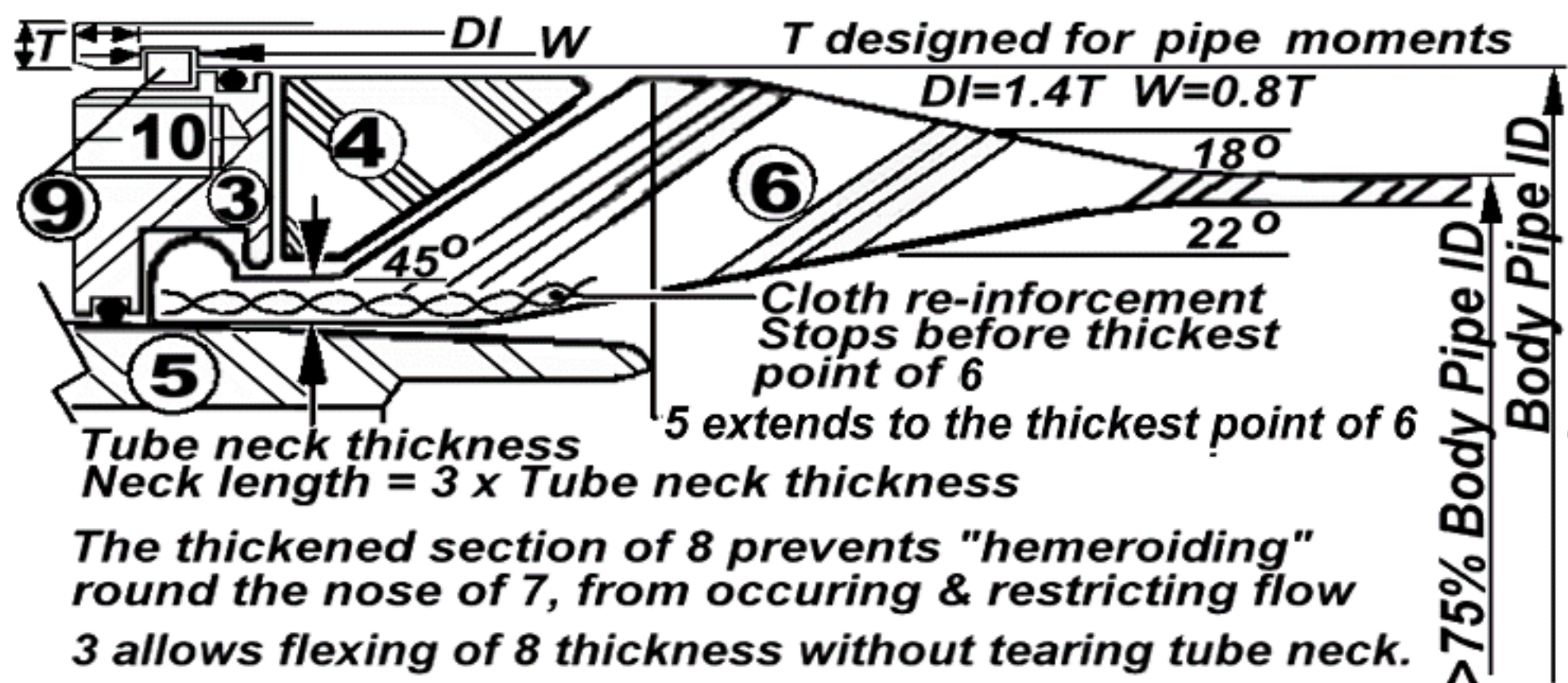
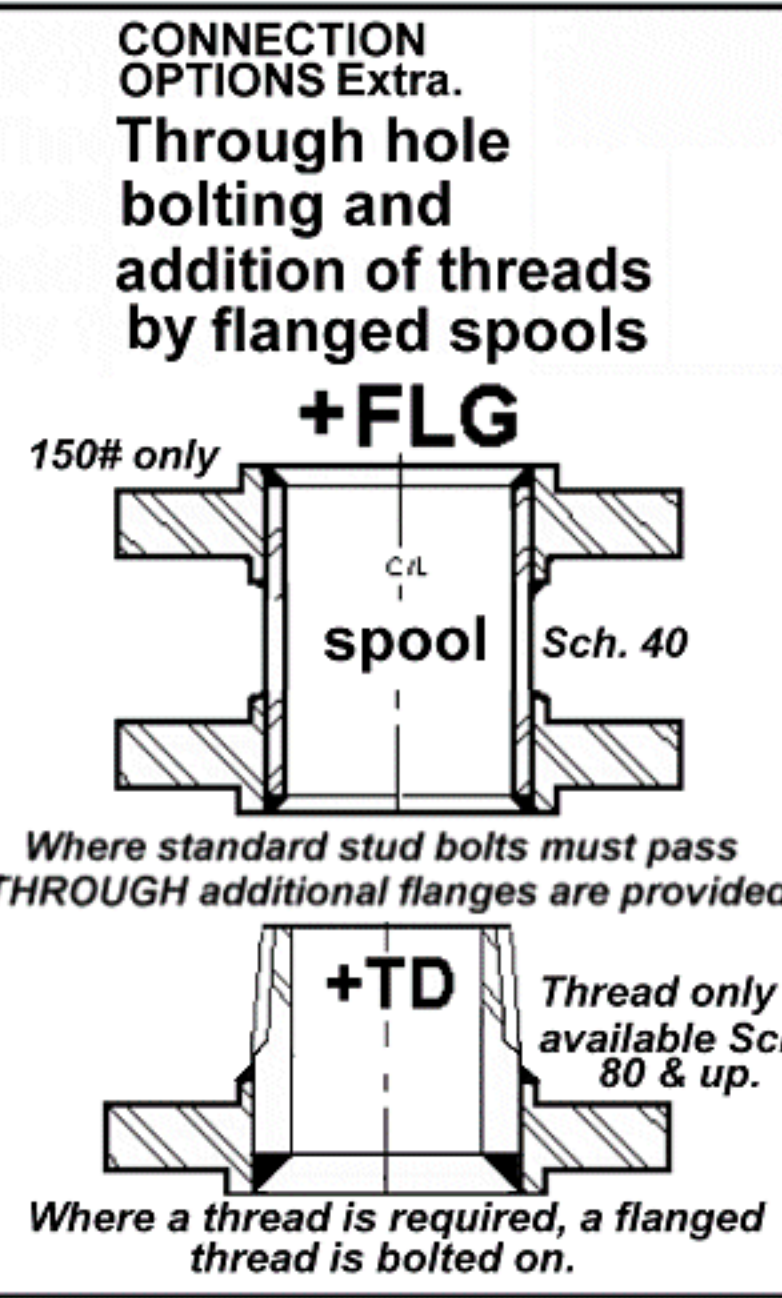
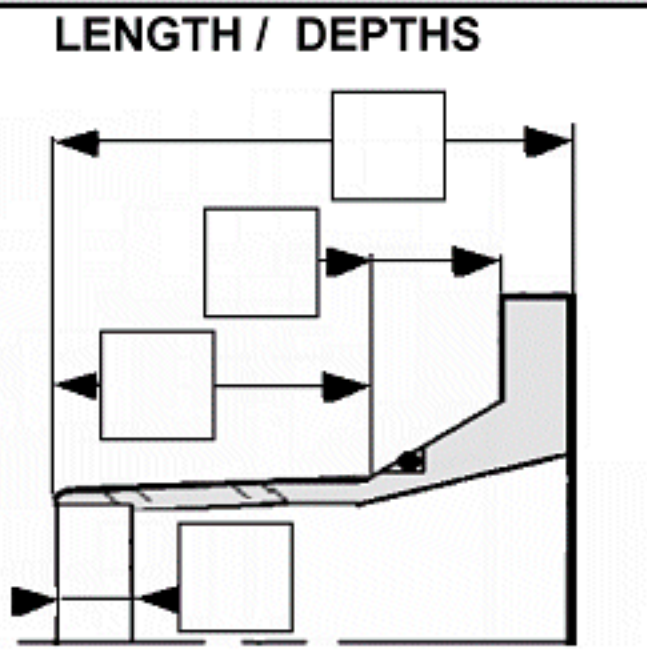
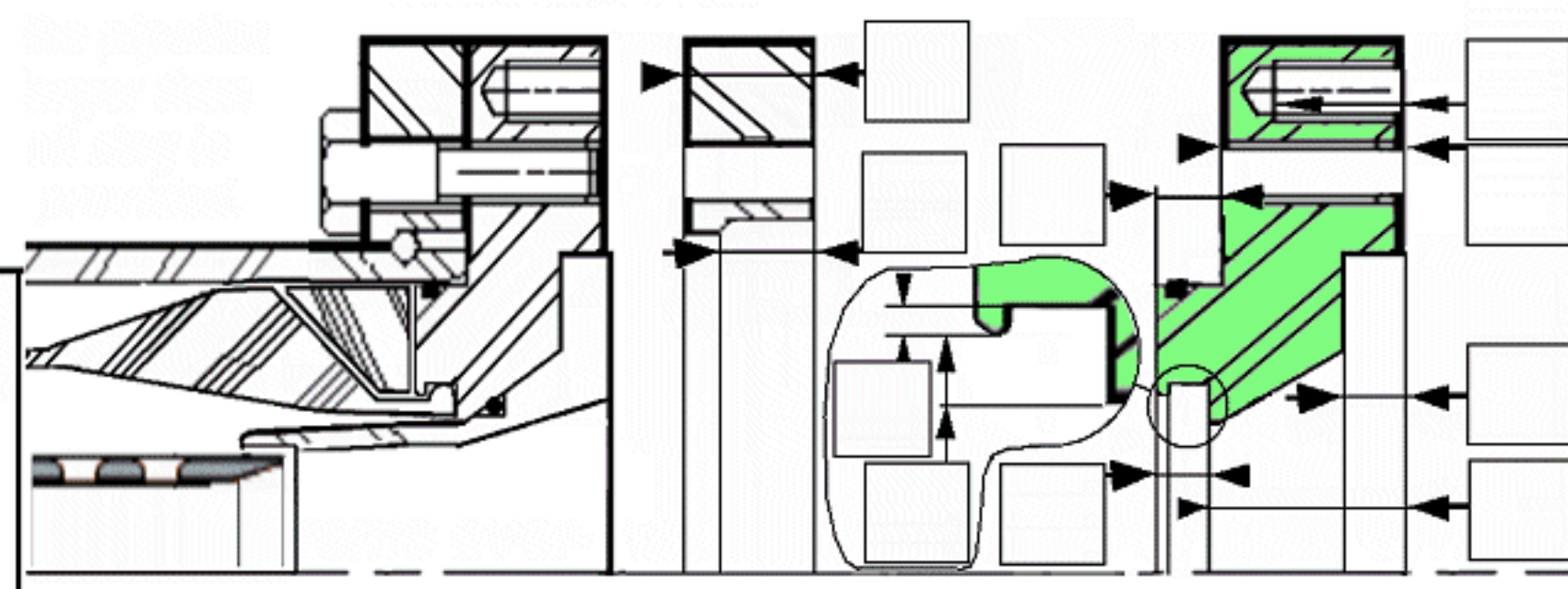

ITEM	PT. Nbr.	DESCRIPTION	MTRL	HT / CAST Nbr.	CUSTOMER
1		TAPPED BOLT HOLE FLANGE / END CVR.	PVQ CS		CUSTOMER REF.
3 <sup>+</sup>		END PLUG WITH SEAL GROOVES	PVQ CS		3rd. PARTY QA. EXTRA
2		BODY PIPE WITH GROOVED ENDS	106B		DOCUMENTATION LEVEL EXTRA
4		CORNER FILLING RING	Rubber		WELDING W: NONE
5		ANCHOR TUBE W/ SEAL & RAISED FACE	316SS		QUANTITY
6		FLEX-TUBE WITH THICKENED ENDS	Elastomer		SHOP / JOB Nbr.
7		ANCHOR TUBE "O" SEAL	E,N,orV		WEIGHT(Est.)
8		END PLUG "O" SEAL	Epdm		ISSUED BY M.P.
9		SEGMENTAL LOCK RING	106		ISSUED DATE Feb 2002
10		FLANGE / CVR. HOLDING SOCKET SCREW	Gr10		CHECKED BY D.B.
11		FOAM CUSHION FOR SUCTION JOBS	Urethane		FILE NAME PugXLrf.bmp
12		GAS CUSHION FILLING VALVE	304ss		SCALE Not To Scale.
13		PERFORATED SUPPORT TUBE	304Lss		Rev. # 0
14	or	STUD BOLT HOLES PER ANSI B 16.5 STUD BOLT HOLES PER DIN DN/PN			DIMENSIONS ARE unless otherwise stated mm
15					

Reading the Pt Nbr. To Suit Specific Pump Type / PumpGuard / With PermaCushion / or / With Perorated Support Tube / Number of in3 capacitance Vol or +Liters / Lbs In2 design pressure / Connections / wetted materials  
HOS=Hose, PROG-C=Progressive Cavity/ "PUG" / "PEC" / or / "PST" / 230 or 4 Lt., 3465 or 57Lt., 12250 or 200Lt., Example 550p = 550 psi / 10" 300# / 316= 316/316L SS

**PULSEGUARD Inc.**  
For the Americas --01(1)910-270-2737  
BW & Color Fax, --01(1)910-270-0320

Drawing / Pt. Nbr. Pug-F&D.typ

IN ASSOCIATION WITH OTHER M. PACKER LICENSEES :-

Flow-Guard.com Flow-Fuses  
S&Accs Ltd Special Accumulators  
ShockGuard USA Pipe Shock Alleviators  
Liquid Dynamics International Inc. Analysis